

## FITTING INSTRUCTION

Clamp mark in acc. with		Cables joining
ISO	PN	
1	L	Left directional lights
2	+	Rear fog lights
3	31	Ground
4	R	Right directional lights
5	58R	Right side parking lights
6	54	Stoplights
7	58L	Left side parking lights

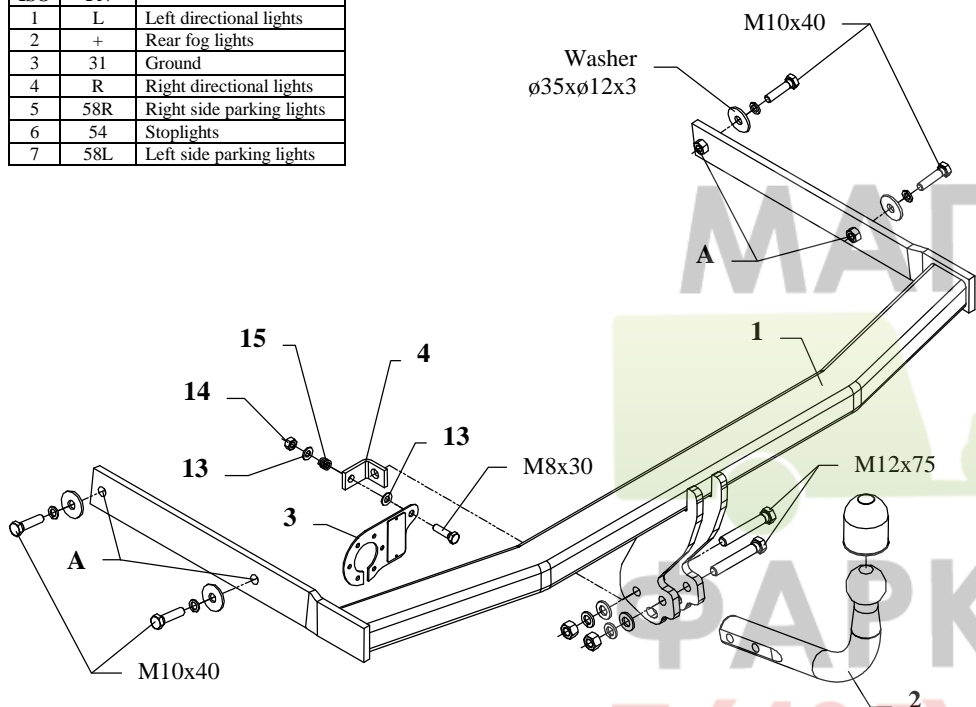

Fig. 1

This towbar is designed to assembly in following cars: **VOLKSWAGEN JETTA**, produced since 2005 and **VOLKSWAGEN GOLF V VARIANT (estate)** produced since 2007, catalogue no. **K49** and is prepared to tow trailers max total weight **1700 kg** and max vertical mass **75 kg**.

### From manufacturer

Thank you for buying our product. Their reliability has been confirmed in many tests. Reliability of towbar depends also on correct assembly and right operation. For this reasons we kindly ask to read carefully this instruction and apply to hints.

*The towbar should be installing in points described by a car producer.*

## The instruction of the assembly

1. For the purpose of installing of the towbar one ought to disassemble the bumper and the metal reinforcement, which will not be reassembled.
2. Make cut outs (see fig. 2) in the bottom of the bumper. If you use moveable socket plate (see fig. 1) it is necessary to cut out major part of the bumper (you need to fit).

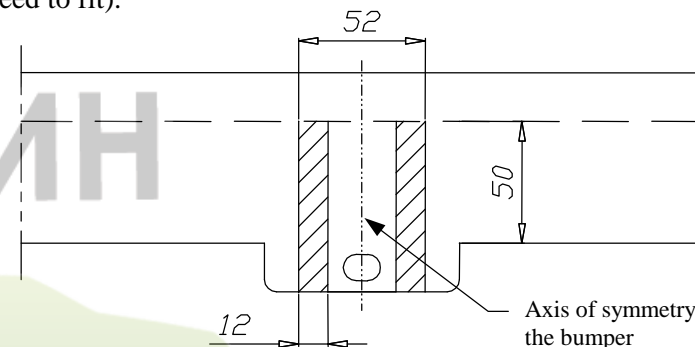

Fig. 2

3. Unscrew the thermal shield from above the muffler.
4. Slip the main bar of the towbar (pos. 1) into chassis members that way so holes with welded nuts (pos. A) be covered with factory-made assembly-holes and fix using bolts M10x40mm (pos. 6). Use washers (pos. 7).
5. Fix tow-ball of the towbar (pos. 2) with handle of socket plate (pos. 4) using bolts M12x75mm (pos. 5).
6. Fix the socket plate (pos. 3) as shown on the drawing.
7. Tighten all bolts according to the torque shown in the table.
8. Connect electric wires of 7-poles socket according to the instruction of the car. (Recommend to make at authorized service station).
9. Complete paint layer damaged during installation.

Torque settings for nuts and bolts (8,8):

<b>M 8</b> - 25 Nm	<b>M 10</b> - 55 Nm
<b>M 12</b> - 85 Nm	<b>M 14</b> - 135 Nm











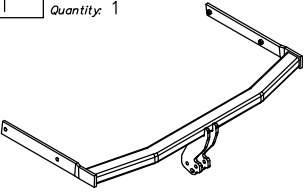
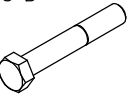

### NOTE

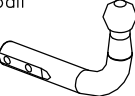
After install the towbar you should get adequate note in registration book (at authorised service station).The car should be equipped with:

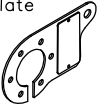
- Indicators
- Tow mirrors

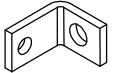
Check all bolts and nuts after 1000km of exploitation. The ball of towbar must be always kept clear and conserve with a grease.

## Towbar equipment:

Pos. 1 Name: Main bar Quantity: 1 	Pos. 5 Name: Bolt 8,8 B Quantity: 2 Dim.: M12x75mm 	Pos. 11 Name: Spring washer Quantity: 4 Dim.: Ø 10,2 mm 
	Pos. 6 Name: Bolt 8,8 B Quantity: 4 Dim.: M10x40mm 	Pos. 12 Name: Bolt 8,8 B Quantity: 1 Dim.: M8x30mm 
Pos. 2 Name: Tow ball Quantity: 1 	Pos. 7 Name: Washer Quantity: 4 Dim.: Ø35xØ12x3mm 	Pos. 13 Name: Plain washer Quantity: 2 Dim.: Ø 8,5 mm 
Pos. 3 Name: Socket plate Quantity: 1 	Pos. 8 Name: Nut 8 B Quantity: 2 Dim.: M12 	Pos. 14 Name: Nut 8 B Quantity: 1 Dim.: M8 
Pos. 4 Name: Handle of socket plate Quantity: 1 	Pos. 9 Name: Plain washer Quantity: 2 Dim.: Ø 13 mm 	Pos. 15 Name: Spring Quantity: 1 
	Pos. 10 Name: Spring washer Quantity: 2 Dim.: Ø 12,2 mm 	Pos. 16 Name: Ball cover Quantity: 1 



**PPUH AUTO-HAK S.J.**

Produkcja Haków Holowniczych  
Henryk & Zbigniew Nejman  
76-200 SŁUPSK ul. Słoneczna 16K  
tel/fax (059) 8-414-414; 8-414-413  
E-mail: [office@autohak.com.pl](mailto:office@autohak.com.pl)  
[www.autohak.com.pl](http://www.autohak.com.pl)

## Towing hitch (without electrical set)

Class: **A50-X** Cat. no. **K49**

Designed for:

Manufacturer: **VOLKSWAGEN**

Model: **JETTA**

produced since 2005 and

Model: **GOLF V Variant (estate)**

produced since 2007

Technical data:

**D-value: 9,3 kN**

maximum trailer weight: **1700 kg**

maximum vertical cup mass: **75 kg**

**Approval number according to Directive 94/20/EC: e20\*94/20\*0088\*00**

## Foreword

This towbar is designed according to rules of safety traffic regulations. The towing hitch is a safety component and can be install only by qualified personnel. Any alteration or conversion of the towing hitch is prohibited and would lead to cancellation of design certification. Remove insulating compound and underseal from vehicle (if present) in the area of the matting surfaces of the towing hitch.

The vehicle manufacturer's specifications regarding trailer load and max. vertical cup load are decisive for driving whereat values for the towing hitch cannot be exceeded.

*D-value formula:*

$$\frac{\text{Max trailer weight [kg]} \times \text{Max vehicle weight [kg]}}{\text{Max trailer weight [kg]} + \text{Max vehicle weight [kg]}} \times \frac{9,81}{1000} = D \text{ [kN]}$$